

403A-11G1

9.5 kWm (Gross) @ 1500 rpm

Electropak

400

Series

Basic technical data

Number of cylinders	3
Cylinder arrangement	Vertical in-line
Cycle	four stroke
Induction system	Naturally aspirated
Compression ratio	23:1
Bore	77 mm
Stroke	81 mm
Cubic capacity	1.131 litres
Direction of rotation	anti-clockwise viewed from flywheel
Firing order	1, 2, 3
Estimated total weight (dry)	129.2 kg

Overall dimensions

Height	702 mm
Length	775 mm
Width (including mounting brackets)	438 mm

Moments of inertia (mk²)

Engine rotational components	0.12 kg m ²
Flywheel	1.51 kg m ²

Centre of gravity

Forward from rear of block	TBA mm
Above crank centre line	TBA mm
Offset to RHS of centre line	TBA mm

Performance

Note: All data based on operation to ISO 3046-1:2002 standard reference conditions.

Steady state speed stability at constant load	± 0.75%
Cyclic irregularity	
@ 110% stand-by power	TBA

Test conditions

Air temperature	25°C
Barometric pressure	100 kPa
Relative humidity	31.5%
Air inlet restriction at maximum power (nominal)	3 kPa
Exhaust back pressure at maximum power (nominal)	10.2 kPa
Fuel temperature (inlet pump)	40°C

Sound level

Average sound pressure level for bare engine (without inlet and exhaust) at 1 metre

76.7 dB(A)

All ratings certified to within

± 5%

If the engine is to operate in ambient conditions other than those of the test conditions, suitable adjustments must be made for these changes. For full details, contact Perkins Technical Service Department.

General installation, 403A-11G1 Electropak @ 1500 rpm

Designation	Units	Type of operation and application	
		Prime	Stand-by
		50 Hz	50 Hz
Gross engine power	kWb	8.6	9.5
Brake mean effective pressure	kPa	610	672
Mean piston speed	m/s	4.1	
Engine coolant flow (Water pump ratio 1.285:1)	l/min	27.3	
Combustion air flow	m ³ /min	0.7	
Exhaust gas flow (max)	m ³ /min	1.66	1.8
Exhaust gas temperature outlet (max)	°C	368	420
Overall thermal efficiency (nett)	%	32	31
Typical genset electrical output (0.8 pf 25°C)	kWe	7.2	8.0
	kVA	9.0	10.0
Assumed alternator efficiency	%	86	

Energy balance

Designation	Units	Type of operation and application	
		Prime	Stand-by
		50 Hz	50 Hz
Energy in fuel (heat of combustion)	kWt	25.9	29.5
Energy in power output (gross)	kWb	8.6	9.5
Energy to cooling fan	kWt	0.2	
Energy in power output (nett)	kWm	8.4	9.3
Energy to coolant and lubricating oil	kWt	8.3	9.5
Energy to exhaust	kWt	7.3	8.0
Heat to radiation	kWt	1.7	2.5

403A-11G1 ElectropaK, left side view

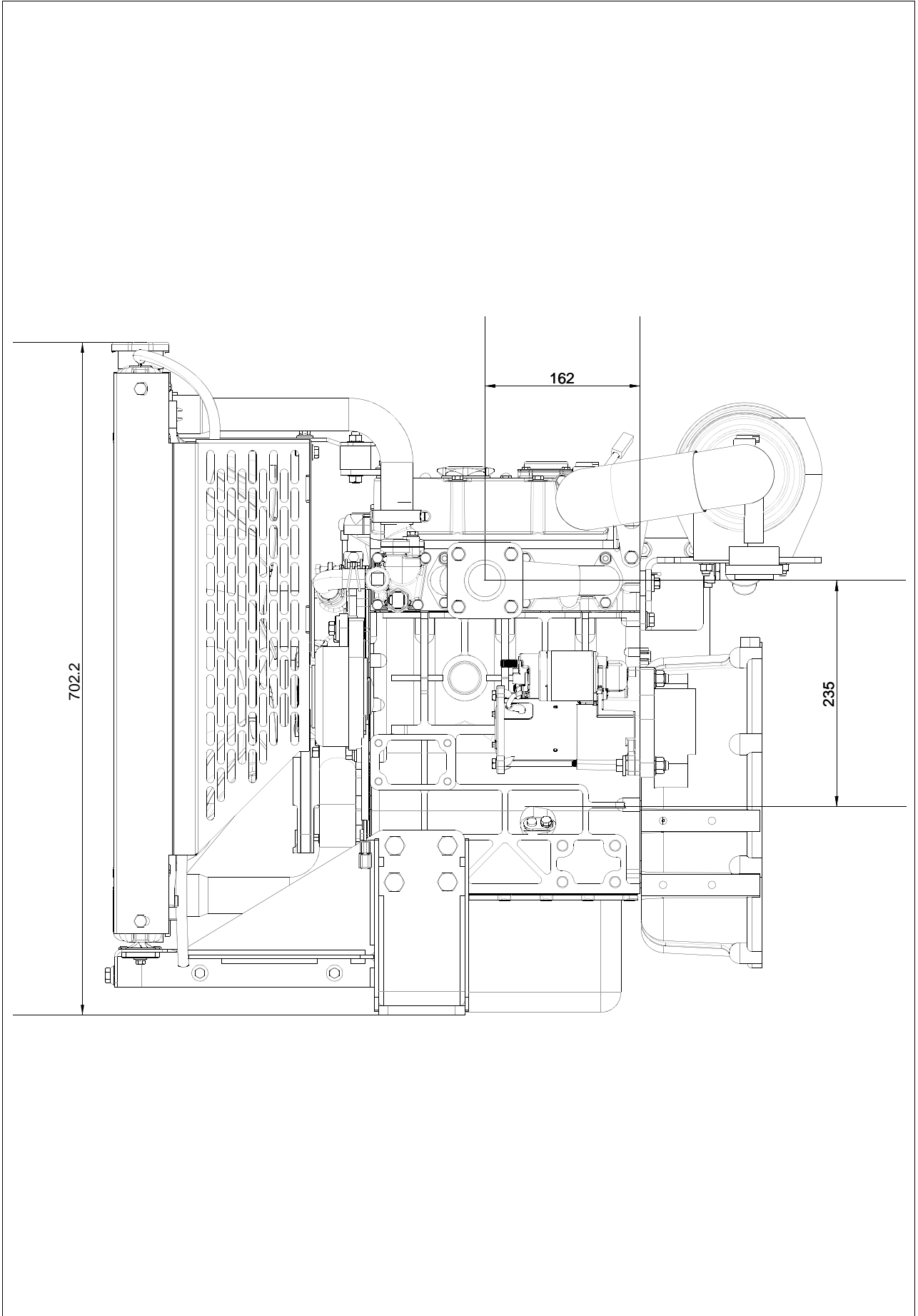

403A-11G1 ElectropaK, front view

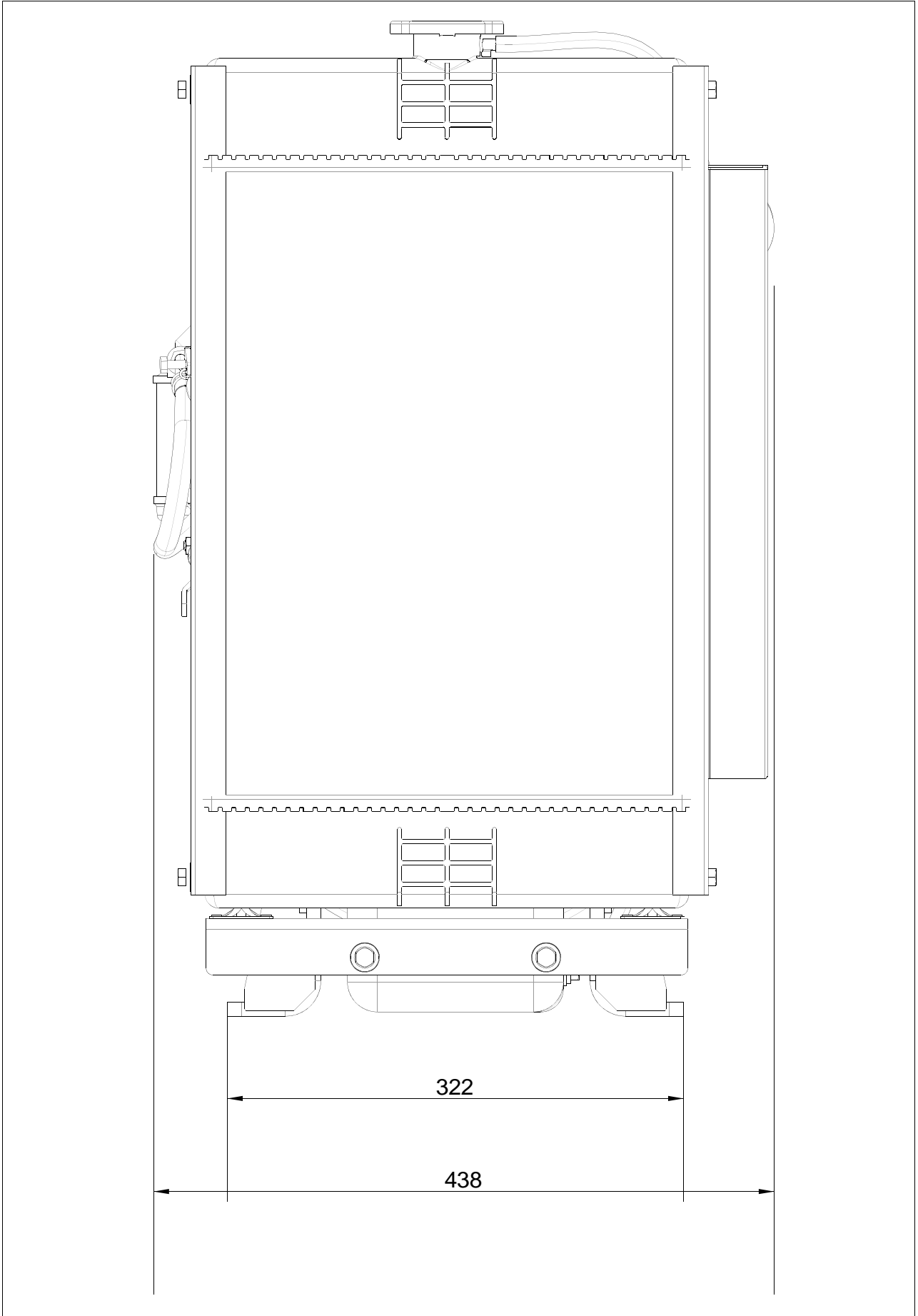

403A-11G1 ElectropaK, right view

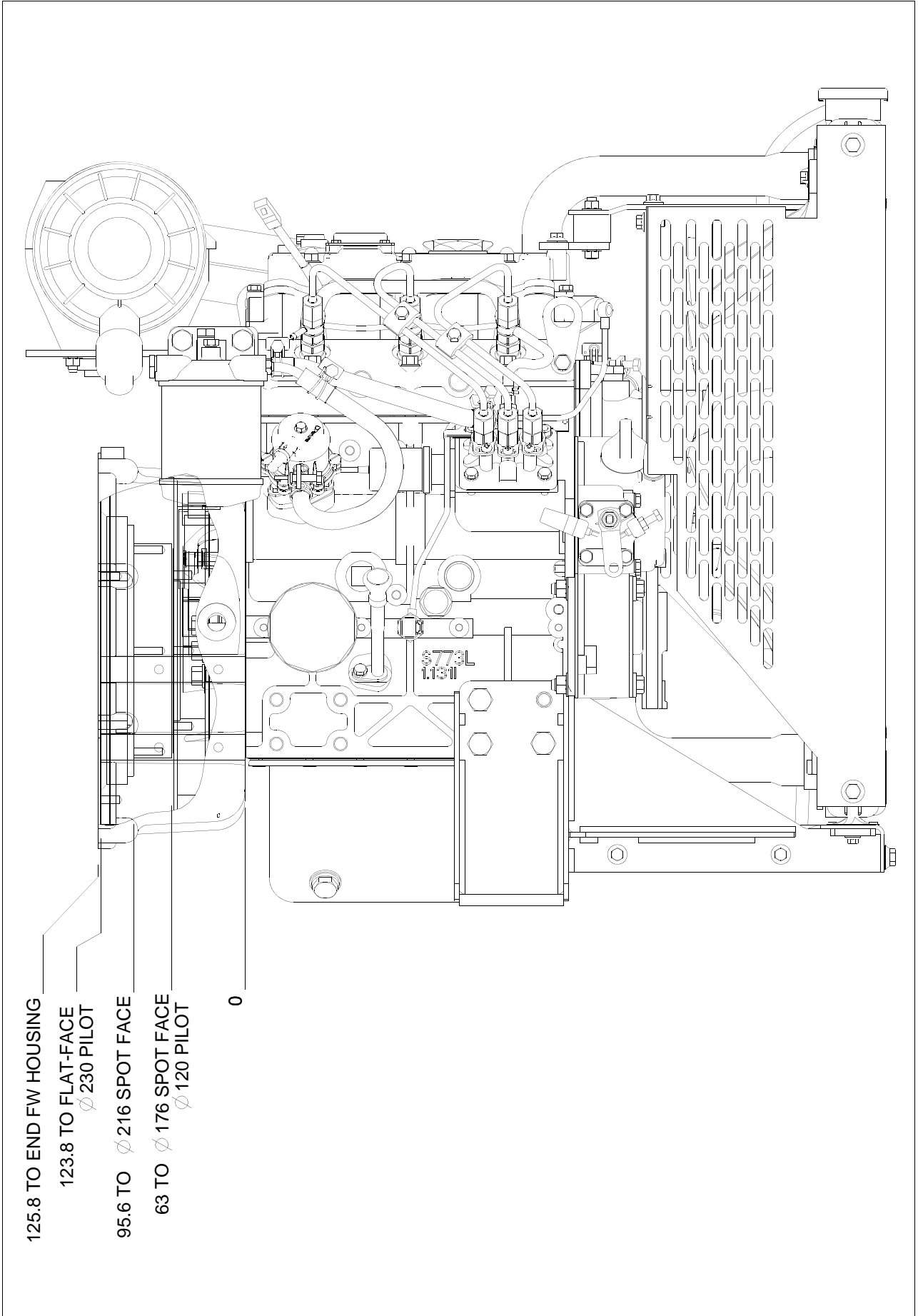

403A-11G1 ElectropaK, rear side view

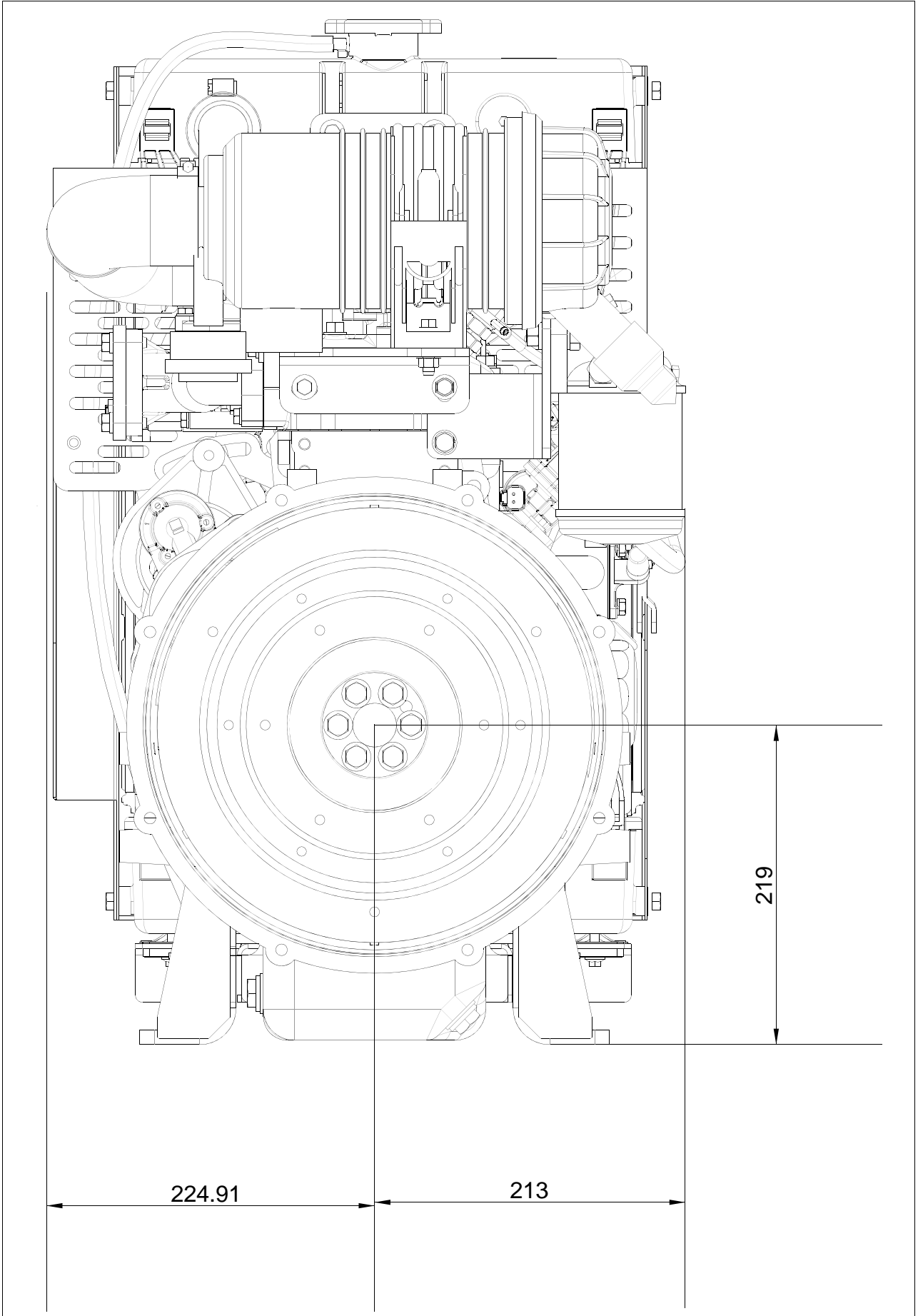

403A-11G1 ElectropaK, plan view

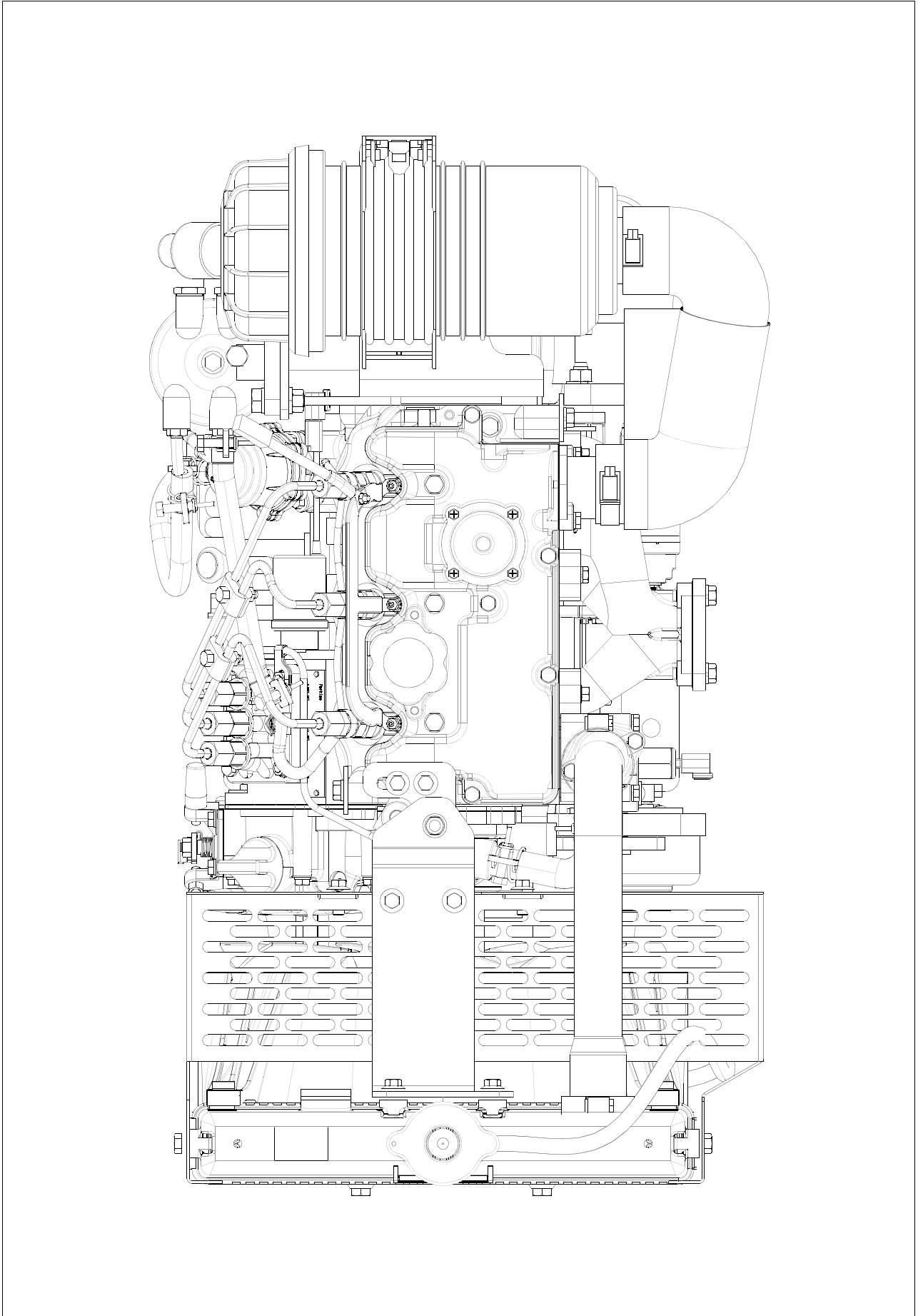

403A-11G1 ElectropaK, underneath view

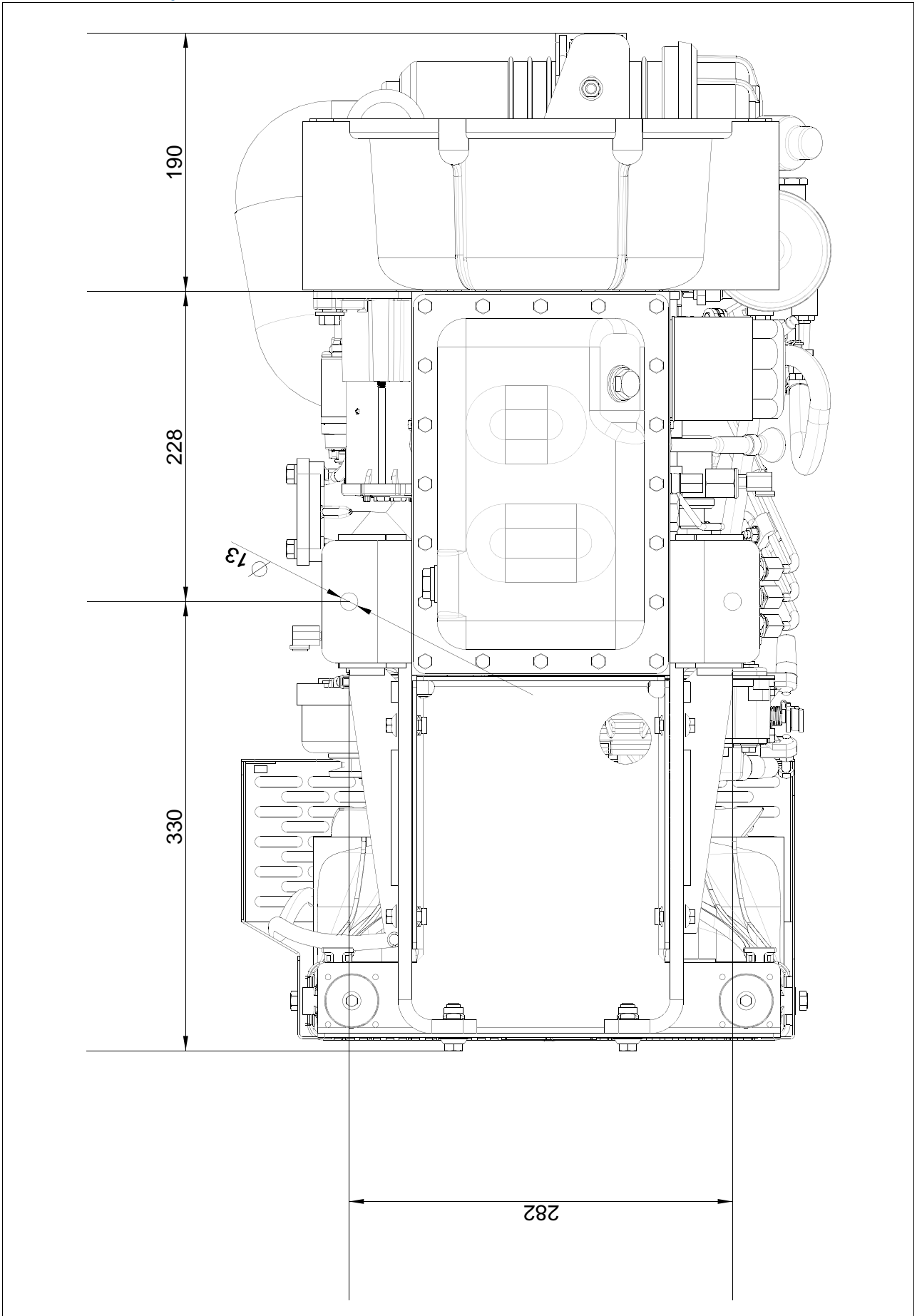

Cooling system

Radiator

-face area	0.147 m ²
-rows and materials	2 rows, Aluminium
-matrix density and material	14.5 fins/inch, Aluminium
-width of matrix	334 mm
-height of matrix	440 mm
-pressure cap setting	90 kPa
Estimated cooling air flow reserve	0.125 kPa

Fan

-diameter	320 mm
-drive ratio	1.285:1
-number of blades	6
-material	Plastic
-type	Pusher

Coolant

Total system capacity	
With radiator	5.2 litres
Without radiator	1.9 litres
Maximum top tank temperature	112°C
Max static pressure head on pump	30.4 kPa
Temperature rise across engine	TBA°C
Max permissible external system resistance	TBA kPa
Thermostat operation range	75 - 87°C
Recommended coolant: 50% anti freeze / 50% water. For complete details of recommended coolant specifications, refer to the Operation and Maintenance Manual for this engine model	

Duct allowance

Maximum additional restriction (duct allowance) to cooling airflow and resultant minimum airflow		
Ambient clearance 50% Glycol	Duct allowance Pa	m ³ /sec
53°C	0	0.67
46°C	125	0.44

Electrical system

Alternator	15 amps, 12 V
Starter motor	1.1 kW, 12 V

Cold start recommendations

Minimum cranking speed.150 rpm

Minimum starting temperature °C	Grade of engine lubricating oil	Battery specifications			
		BS3911 Cold start amps	SAEJ537 Cold cranking amps	No. of batteries needed	Commercial ref number
0	20W	340	540	1	069
-15	10W	340	540	1	069
-20	5W	420	590	1	072

Note: Additional information for battery and cable limits can be found in Chapter 6 of the 400 Series Engine Sales Manual.

Exhaust system

Maximum back pressure	10.2 kPa
Exhaust outlet size	
-horizontal	34 mm
-vertical	40 mm

Fuel system

Type of injection	Indirect injection
Fuel injection pump	Cassette type
Fuel injector	Pintle nozzle
Nozzle opening pressure	14.7 MPa
Maximum particle size	25 microns

Fuel lift pump

Type	mechanical (camshaft driven)
Flow/hour	63 litres/hr
Pressure	10 kPa
Maximum suction head	0.8 m
Maximum static pressure head	3 m
Governor type	Mechanical

Fuel specification

USA Fed Off Highway - EPA2D 89.330-96

Europe Off Highway - CEC RF-06-99

Note: For further information on fuel specifications and restrictions, refer to the OMM Fuels section for this engine model

Fuel consumption

Power rating			
g/kWh (litres/hr)			
110%	100%	75%	50%
261 (2.9)	252 (2.6)	258 (2.0)	286 (1.5)

Induction system

Maximum air intake restriction

- clean filter ... 3.0 kPa
- dirty filter6.4 kPa
- air filter type Dry element type

Lubrication system

Lubricating oil capacity

- Maximum sump capacity 4.4 litres
- Total system 4.9 litres
- Minimum sump capacity 3.4 litres
- Maximum engine operating angles
- front up, front down, right side or left side 35° continuous

Lubricating oil pressure

- minimum oil pressure 120 kPa
- relief valve opens 304 - 500 kPa
- at maximum no-load speed TBA
- Normal oil temperature 125°C
- oil flow at rated speed. 6.6 litres/min.

Recommended SAE viscosity

A single or multi grade oil must be used which conforms API-CH-4 or ACEA E5.

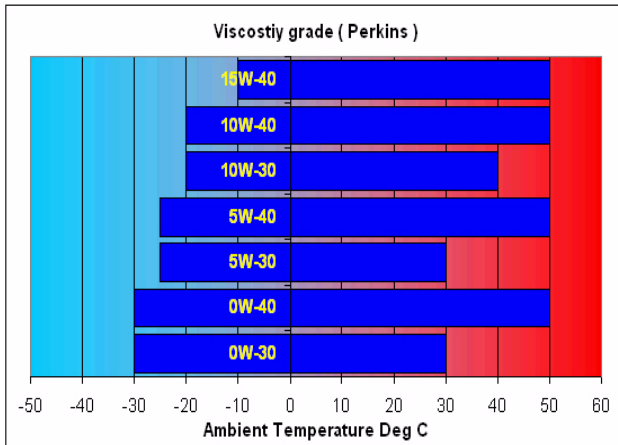

Maximum static bending moment

at rear face of block 500 Nm

Load acceptance

The below complies with the requirements of classification 3 and 4 of ISO 8528-12 and G2 operating limits stated in ISO 8528-5

Initial load application: When engine reaches rated speed (15 seconds maximum after engine starts to crank)		
Descriptor	Units	50 Hz
% of prime power	%	TBA
Transient frequency deviation	%	TBA
Frequency recovery	Seconds	TBA

The above figures were obtained under the following test conditions:

- minimum engine block temperature. TBA°C
 - ambient temperature 25°C
 - governing mode 5 %
 - alternator inertia TBA kgm²
 - under frequency roll off (UFRO) point set to 2% Volt / 1% frequency
 - UFRO rate set to 1 Hz below rated speed
 - LAM on/off. off
- All tests were conducted using an engine which was installed and serviced to Perkins Engines Company Limited recommendations.

Derate Curves

Derate curves for altitude and humidity can be found in Chapter 6 of the 400 Series Engine Sales Manual.

Note: The general arrangement drawings shown in this data sheet are for guidance only. For installation purposes, latest versions should be requested from the Applications Dept., Perkins Engines Stafford, ST16 3UB United Kingdom.